

Semi-Portable Refill Station XS-RS-03-TM

meetpat Product Range



Product Description

meetpat semi-portable bottle refill station is suitable for both indoor and outdoor environments.

This hybrid water station is ideal for high volume, longer and larger events. With a lead free plumbing system and anti-bacterial bottle refill dispenser. Polycarbonate graphics panels with anti-graffiti protection. Non-refrigerated.

Suitable as a stand alone unit or interconnect multiple units with the joiner hose kit for larger events.

Product Specifications & Inclusions	
Tapware/ Touch Free Sensor	Infrared sensor with impact resistant lens. Located inside bottle refill window. 4x AA batteries. 100,000 activations (2-3 years for battery life)
Frame	304SS and aluminium (powdercoated)
Base	HDPE with non slip surface
Nozzles	316SS stainless steel
Water Pressure	Max. 500kPa operating pressure (5 bar) Min. 120kPa operating pressure (1.2 bar)
Panel Finish	2mm clear unbranded polycarbonate
Flow Rate	4.5L per minute (pressure dependent)
Working Temp	1°C minimum 38°C maximum
Lighting	Solar with automatic low light sensor
Connectors	2x stainless steel 1/2" threaded connectors
Power	No electrical connection required
Warranty	1 year standard. Refer meetpat product warranty for full T&Cs.

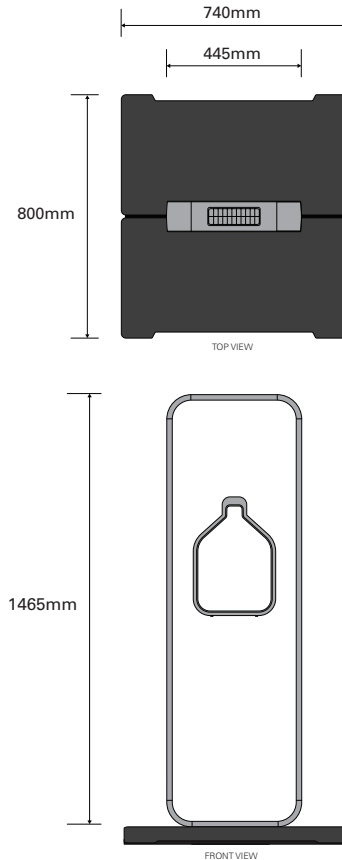

Accessories (Optional Extras)		
PT-HK-01-WM	Drink Safe Hose Kit	10M drainage hose. 10M water supply hose. Tap adapter.
PT-JK-01	Joiner Hose Kit	Drainage and water supply to link multiple refill stations
AX-FS-01	Water Filter - sml	11,000L capacity
AX-FR-01	Water Filter - reg	22,000L capacity
AX-FL-01	Water Filter - lrg	55,000L capacity
PM-TK-01	Tall Extension Kit	The solar illuminated branded box. With 2mm clear unbranded polycarbonate panels.
EX-DM-01 Available 2024	Digital Water Meter Kit	E-Ink display. Inc flow meter and wiring.
TX-LT-01-915	LoRaWAN Smart Water Meter Kit	Australia, USA, Asia 915/923MHz
TX-LT-01-868	LoRaWAN Smart Water Meter Kit	Middle East, Europe 868MHz
EX-CC-01 Available 2024	Core Controller Kit	Auto control module. Inc low temperature analysis, auto-flushing, freeze resistance and water quality monitoring.

Packaged Details

Product	Weight	Packed Size*
XS-Refill Station	27kg	150cm x 50cm x 13cm
XS-Base	6kgs	76cm x 25cm x 12cm
XS-Ramp Set	10.5kgs	76cm x 45cm x 5cm
PM-Panels	5kgs	140cm x 44cm x 2cm

XS-RS-03-TM includes boxed: refill station, base & panels
*packed size varies depending on quantity and accessories ordered



Graphics & Printing for Panels (select option)

Unbranded (no printing) Blank Graphics	No graphics printing supplied.
meetpat blue Standard Graphics	meetpat standard graphics. Printed and applied to panels.
Customised Printing Unique Graphics	meetpat assisted* personalised graphic design. Printed and applied to panels.

*graphics design service includes, design development and guidance, artwork proofs & two revisions

All information and images contained in the document are © Meet PAT™ - Meet PAT Pty Ltd or their respective owners. They are not be used without consent from Meet PAT™. As improvements in the design and performance of Meet PAT products are continuous, specifications may be subject to change without notice. This technical sheet is copyright and owned by Meet PAT™ - Meet PAT Pty Ltd ABN 48163544278. All rights are reserved. All products and sales are subject to Meet PAT™ terms and conditions.

Semi-Portable Refill Station XS-RS-03-TM

meetpat Product Range



Product Overview

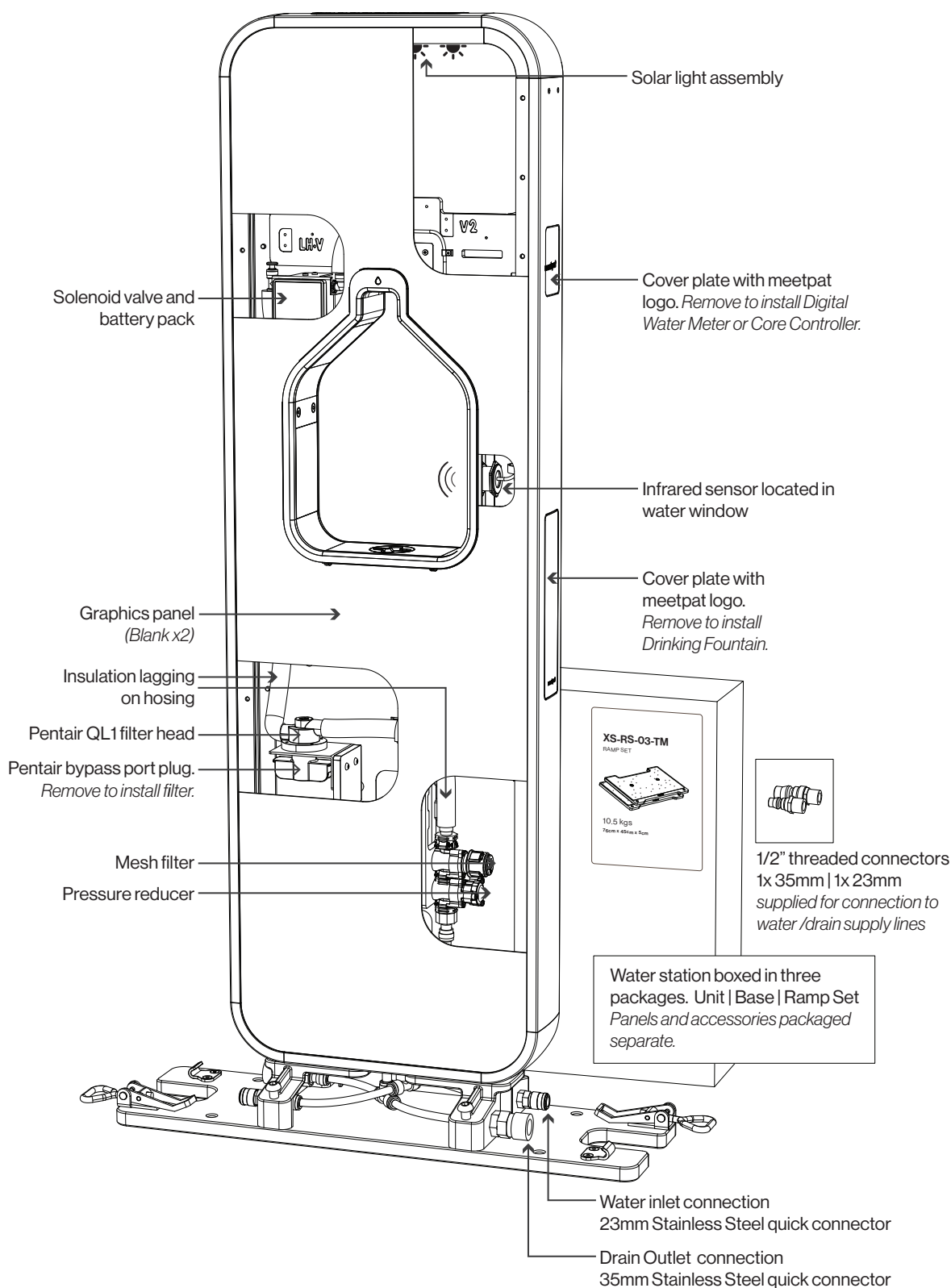

All information and images contained in the document are © Meet PAT™ - Meet PAT Pty Ltd or their respective owners. They are not be used without consent from Meet PAT™. As improvements in the design and performance of Meet PAT products are continuous, specifications may be subject to change without notice. This technical sheet is copyright and owned by Meet PAT™ - Meet PAT Pty Ltd ABN 48163544278. All rights are reserved. All products and sales are subject to Meet PAT™ terms and conditions.

Hose Kit PT-HK-01-WM

meetpat Accessories

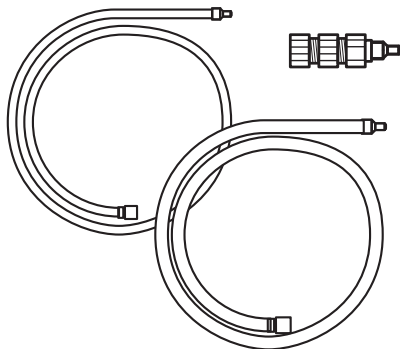

Product Description

An easy to fit, safe water hose kit, adds reliable connection and drainage for the portable and the semi-portable refill stations.

The kit comes complete with; 1x water supply hosing, 1x drainage hosing and 2x tap adapters (AUS / US). The kit enables a single water station set up, to suitable water inlet and outlet hosing to drainage point.

Compatible with PT-RS-03 or XS-RS-03-TM*

*must connect from/to same model/type of refill station

All kit parts can pack easily into the portable carry bag PT-CB-03 (purchased separately).

Product Specifications & Inclusions	
Hose Material	Non-toxic. Food grade poly-olefin.
Tap Adaptor	Stainless Steel 1" Threaded Adapter 3/4" Threaded Adapter 3/4" US GHT Threaded Adapter
Hose Size	10 meter water supply hose 10 meter drainage hose
Fixings	23mm Female water supply connection 35mm Drainage connection
Assembly	Quick connect barb fitting
Warranty	1 year standard. Refer meetpat product warranty for full T&Cs.
Replacement	Available from meetpat. Reorder code: PT-HK-01-WM

Packaged Details		
Product	Weight	Packed Size*
PT-HK-01-WM	2.9kg	52cm x 50cm x 12.5cm

*packed size varies depending on quantity and accessories ordered

All information and images contained in the document are © Meet PAT™ - Meet PAT Pty Ltd or their respective owners. They are not be used without consent from Meet PAT™. As improvements in the design and performance of Meet PAT products are continuous, specifications may be subject to change without notice. This technical sheet is copyright and owned by Meet PAT™ - Meet PAT Pty Ltd ABN 48163544278. All rights are reserved. All products and sales are subject to Meet PAT™ terms and conditions.

Meet Pat™ | Meet PAT Pty Ltd | meetpat.com
(02) 6021 0300, +612 6021 0300 | sales@meetpat.com

meetpat®

Joiner Hose Kit PT-JK-01-WM

meetpat Accessories

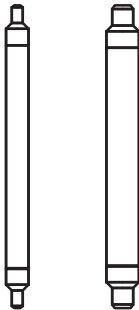

Product Description

The quick connection, joiner hose kit, adds a reliable attachment between multiple refill stations. Creating a wall or bank of products for additional refill outlets at a single location.

Compatible with PT-RS-03 or XS-RS-03-TM*

*must connect from/to same model/type of refill station

The kit comes complete with; 2x joiner hose, enabling the connection of two refill stations. All additional refill stations require multiple kits to be purchased.

All kit parts can pack easily into the portable carry bag PT-CB-03 (purchased separately).

Product Specifications & Inclusions	
Hose Material	Non-toxic. Food grade poly-olefin.
Connector Material	Stainless steel
Joiner Size	360mm
Fixings	23mm Female water supply connection 35mm Drainage connection
Assembly	Quick connect barb fitting
Warranty	1 year standard. Refer meetpat product warranty for full T&Cs.
Replacement	Available from meetpat. Reorder code: PT-JK-01-WM

Packaged Details		
Product	Weight	Packed Size*
PT-JK-01	400gm	8.1cm x 8.1cm x 43cm

*packed size varies depending on quantity and accessories ordered

All information and images contained in the document are © Meet PAT™ - Meet PAT Pty Ltd or their respective owners. They are not to be used without consent from Meet PAT™. As improvements in the design and performance of Meet PAT products are continuous, specifications may be subject to change without notice. This technical sheet is copyright and owned by Meet PAT™ - Meet PAT Pty Ltd ABN 48163544278. All rights are reserved. All products and sales are subject to Meet PAT™ terms and conditions.

Meet Pat™ | Meet PAT Pty Ltd | meetpat.com
(02) 6021 0300, +612 6021 0300 | sales@meetpat.com

meetpat®

Water Filter AX-FR-01

meetpat accessories

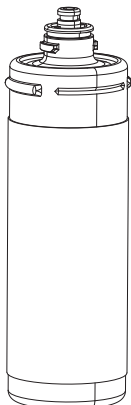

Product Description

Water filter is compatible with both permanent and portable refill stations.

Product effectively filters dirt and particles as small as 5 microns. Inhibits the growth of bacteria, reduces chlorine taste and odour and improves the taste of the water.

Compatible with all Refill Stations;
PT-RS-03 & XS-RS-03-TM & PM-RS-03 (GM & WM)

Product Specifications & Inclusions	
Rated Capacity	22,000 litres
Flow Rate	3L per minute (pressure dependent)
Working Temp	1°C minimum 38°C maximum
Service Flow Rate	5.67 Lpm
Connections	Hand fit to water station. No tools required.
Power	No electrical connection required
Warranty	1 year standard. Refer meetpat product warranty for full T&Cs.
Replacement	Available from meetpat. Reorder code: AX-FR-01

Packaged Details		
Product	Weight	Packed Size*
AX-FS-01	tbc	cm x cm x cm
AX-FR-01	550gm	27cm x 10cm x 10cm
AX-FL-01	tbc	cm x cm x cm

*packed size varies depending on quantity and accessories ordered

All information and images contained in the document are © Meet PAT™ - Meet PAT Pty Ltd or their respective owners. They are not be used without consent from Meet PAT™. As improvements in the design and performance of Meet PAT products are continuous, specifications may be subject to change without notice. This technical sheet is copyright and owned by Meet PAT™ - Meet PAT Pty Ltd ABN 48163544278. All rights are reserved. All products and sales are subject to Meet PAT™ terms and conditions.

**Meet Pat™ | Meet PAT Pty Ltd | meetpat.com
(02) 6021 0300, +612 6021 0300 | sales@meetpat.com**

meetpat®

Tall Extension Kit PM-TK-01

meetpat Accessories

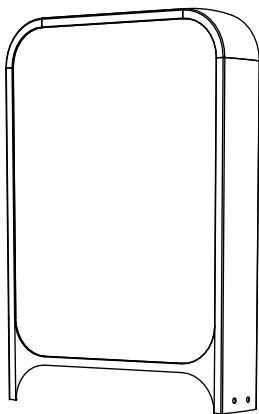

Product Description

Designed to help you stand out in a crowd.

The solar illuminated tall extension kit* is easily fitted to the top of a permanent refill station. Manufactured using the same materials and technology for a uniform appearance.

*Maximum of 1 per water station

Product Specifications & Inclusions	
Frame	Aluminum (powdercoated)
Lighting	Solar with automatic low light sensor
Power	No electrical connection required
Finished Size	685cm x 445cm x 10cm
Compatibility	PM-RS-03-GM
Warranty	3 year standard. 10 year structural warranty on stainless steel frame construction. Refer meetpat product warranty for full T&Cs.

Packaged Details		
Product	Weight	Packed Size*
PM-TK-01	9kgs	75cm x 50cm x 15cm

includes boxed: tall kit & panels

*packed size varies depending on quantity and accessories ordered

All information and images contained in the document are © Meet PAT™ - Meet PAT Pty Ltd or their respective owners. They are not be used without consent from Meet PAT™. As improvements in the design and performance of Meet PAT products are continuous, specifications may be subject to change without notice. This technical sheet is copyright and owned by Meet PAT™ - Meet PAT Pty Ltd ABN 48163544278. All rights are reserved. All products and sales are subject to Meet PAT™ terms and conditions.

**Meet Pat™ | Meet PAT Pty Ltd | meetpat.com
(02) 6021 0300, +612 6021 0300 | sales@meetpat.com**

meetpat®