

# Portable Refill Station PT-RS-03

meetpat Product Range

meetpat®

## Product Description

meetpat portable bottle refill station is suitable for both indoor and outdoor environments.

This water station is lightweight and is manufactured using stainless steel and powdercoated aluminium. With a lead free plumbing system and anti-bacterial bottle refill dispenser. Polycarbonate graphics panels with anti-graffiti protection. Non-refrigerated.

Suitable as a stand alone unit or interconnect multiple units with the joiner hose kit for larger events.

Product Specifications & Inclusions	
Tapware/ Touch Free Sensor	Infrared sensor with impact resistant lens. Located inside bottle refill window. 4x AA batteries. 100,000 activations (2-3 years for battery life)
Frame	304SS and aluminium (powdercoated)
Base	Rotational moulded HDPE
Nozzles	316SS stainless steel
Water Pressure	Max. 500kPa operating pressure (5 bar) Min. 120kPa operating pressure (1.2 bar)
Panel Finish	2mm clear unbranded polycarbonate
Flow Rate	4.5L per minute (pressure dependent)
Working Temp	1°C minimum 38°C maximum
Connectors	2x stainless steel 1/2" threaded connectors
Power	No electrical connection required
Warranty	1 year standard. Refer meetpat product warranty for full T&Cs.

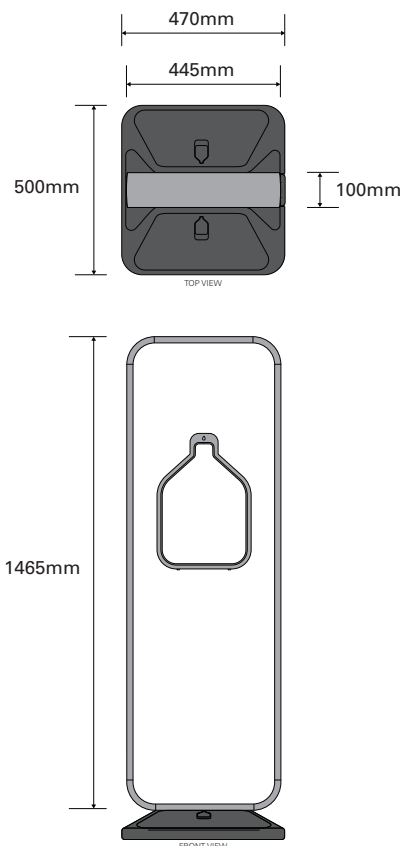

Accessories		
PTHK-01-WM	Drink Safe Hose Kit	10M drainage hose. 10M water supply hose. Tap adapters.
PTJK-01-WM	Joiner Hose Kit	Drainage and water supply to link multiple refill stations
PTCB-03	Portable Carry Bag	Nylon bag with shoulder strap & wheels. Water proof interior. Storage pockets.
AXFR-01	Water Filter	5 micron inline cartridge. Reduces bacteria. Improves taste. 22,000L capacity.
PTBK-01	Bolt Down Kit	HDPE with non slip surface. Bolt down fixings to regular portable base.
EXDM-01 Available 2024	Digital Water Meter Kit	E-Ink display. Inc flow meter and wiring.
TXLT-01-915	LoRaWAN Smart Water Meter Kit	Australia, USA, Asia 915/923MHz
TXLT-01-868	LoRaWAN Smart Water Meter Kit	Middle East, Europe 868MHz
EXCC-01 Available 2024	Core Controller Kit	Auto control module. Inc low temperature analysis, auto-flushing, freeze resistance and water quality monitoring.

Packaged Details		
Product	Weight	Packed Size*
PT-Refill Station	14.5kgs	150cm x 50cm x 13cm
PT-Base	4.7kgs	52cm x 50cm x 12.5cm
PT-Panels	3.2kgs	140cm x 44cm x 2cm

PT-RS-03 includes boxed: refill station, base & panels  
\*packed size varies depending on quantity and accessories ordered



Graphics & Printing for Panels (select option)	
Unbranded (no printing) Blank Graphics	No graphics printing supplied.
meetpat blue Standard Graphics	meetpat standard graphics. Printed and applied to panels.
Customised Printing Unique Graphics	meetpat assisted* personalised graphic design. Printed and applied to panels.

\*graphics design service includes, design development and guidance, artwork proofs & two revisions

All information and images contained in the document are © Meet PAT™ - Meet PAT Pty Ltd or their respective owners. They are not be used without consent from Meet PAT™. As improvements in the design and performance of Meet PAT products are continuous, specifications may be subject to change without notice. This technical sheet is copyright and owned by Meet PAT™ - Meet PAT Pty Ltd ABN 48163544278. All rights are reserved. All products and sales are subject to Meet PAT™ terms and conditions.

# Portable Refill Station PT-RS-03

meetpat Product Range



## Product Overview

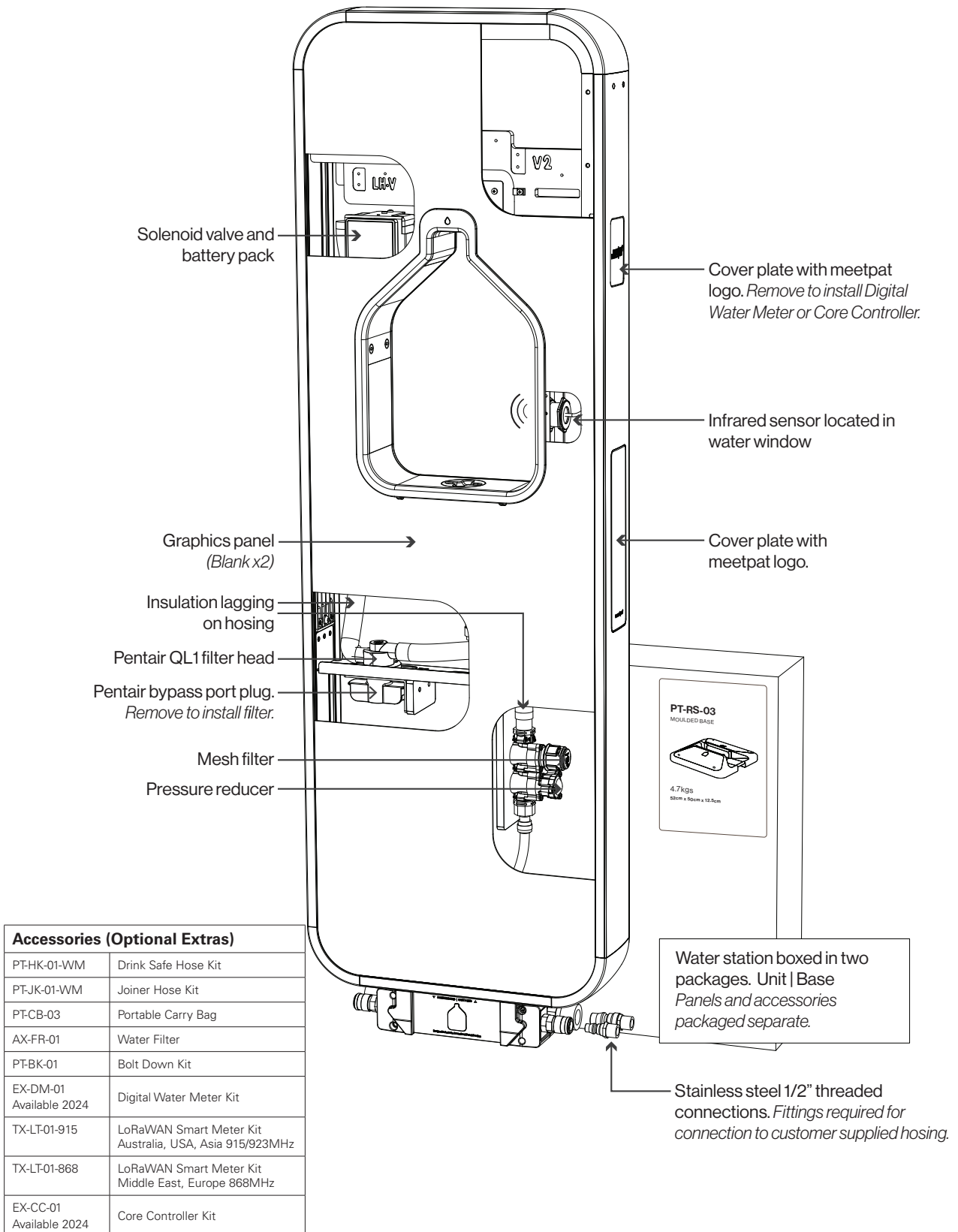

All information and images contained in the document are © Meet PAT™ - Meet PAT Pty Ltd or their respective owners. They are not be used without consent from Meet PAT™. As improvements in the design and performance of Meet PAT products are continuous, specifications may be subject to change without notice. This technical sheet is copyright and owned by Meet PAT™ - Meet PAT Pty Ltd ABN 48163544278. All rights are reserved. All products and sales are subject to Meet PAT™ terms and conditions.