

Permanent Refill Station PM-RS-03-GM

meetpat Product Range



Product Description

meetpat permanent freestanding bottle refill station is suitable for outdoor environments.

This water station is mounted to a heavy duty base bollard and is manufactured using stainless steel and powdercoated aluminium. With a lead free plumbing system and anti-bacterial bottle refill dispenser.

Polycarbonate graphics panels with anti-graffiti protection. Solar lighting for increased visibility. Non-refrigerated.

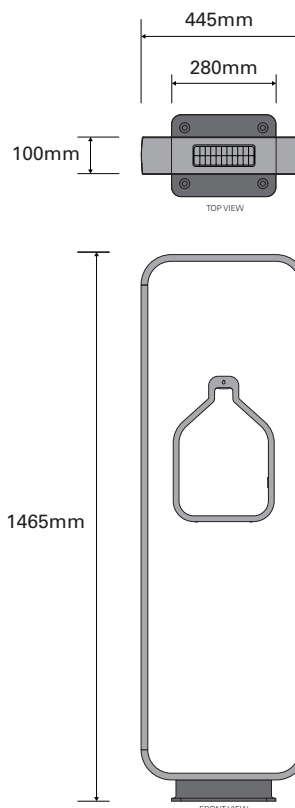

| Product Specifications & Inclusions | |
|-------------------------------------|---|
| Tapware/ Touch Free Sensor | Infrared sensor with impact resistant lens. Located inside bottle refill window. 4x AA batteries. 100,000 activations (2-3 years for battery life) |
| Frame | SS304 and aluminium (powdercoated) |
| Chassis/Bollard | SS304 stainless steel |
| Nozzles | SS316 stainless steel |
| Water Pressure | Max. 500kPa operating pressure (5 bar) Min. 120kPa operating pressure (1.2 bar) |
| Panel Finish | 2mm clear unbranded polycarbonate |
| Flow Rate | 4.5L per minute (pressure dependent) |
| Working Temp | 1°C minimum 38°C maximum |
| Lighting | Solar with automatic low light sensor |
| Power | No electrical connection required |
| Warranty | 3 year standard. 10 year structural warranty on stainless steel frame construction. Refer meetpat product warranty for full T&Cs. |

| Accessories (optional) | | |
|----------------------------|--|---|
| PM-TK-01 | Tall Extension Kit | The solar illuminated branded box. With 2mm clear unbranded polycarbonate panels. |
| PM-AK-01 | Drinking Fountain Kit max 2 per station | Cast stainless fountain, configurable to DDA compliant heights. Touch free operation and braille. |
| PM-DB-02 | Dog Bowl with Sub Surface Pit | Full stainless steel pit. Delivering fresh pet water. |
| AX-FS-01 | Water Filter - sml | 11,000L capacity |
| AX-FR-01 | Water Filter - reg | 22,000L capacity |
| AX-FL-01 | Water Filter - lrg | 55,000L capacity |
| EX-DM-01 Available 2024 | Digital Water Meter Kit | E-Ink display. Inc flow meter and wiring. |
| TX-LT-01-915 | LoRaWAN Smart Water Meter Kit | Australia, USA, Asia 915/923MHz |
| TX-LT-01-868 | LoRaWAN Smart Water Meter Kit | Middle East, Europe 868MHz |
| EX-CC-01 Available 2024 | Core Controller Kit | Auto control module. Inc low temperature analysis, auto-flushing, freeze resistance and water quality monitoring. |

Packaged Details

| Product | Weight | Packed Size* |
|-------------|--------|---------------------|
| PM-RS-03-GM | 40kgs | 150cm x 50cm x 13cm |
| PM-Panels | 5kgs | 140cm x 44cm x 2cm |

Includes boxed: refill station, base & panels
*packed size varies depending on quantity and accessories ordered



Graphics & Printing for Panels (select option)

| | |
|---|---|
| Unbranded (no printing) Blank Graphics | No graphics printing supplied. |
| meetpat blue Standard Graphics | meetpat standard graphics. Printed and applied to panels. |
| Customised Printing Unique Graphics | meetpat assisted* personalised graphic design. Printed and applied to panels. |

*graphics design service includes, design development and guidance, artwork proofs & two revisions

All information and images contained in the document are © Meet PAT™ - Meet PAT Pty Ltd or their respective owners. They are not be used without consent from Meet PAT™. As improvements in the design and performance of Meet PAT products are continuous, specifications may be subject to change without notice. This technical sheet is copyright and owned by Meet PAT™ - Meet PAT Pty Ltd ABN 48163544278. All rights are reserved. All products and sales are subject to Meet PAT™ terms and conditions.

Permanent Refill Station PM-RS-03-GM

meetpat Product Range

meetpat®

Product Overview

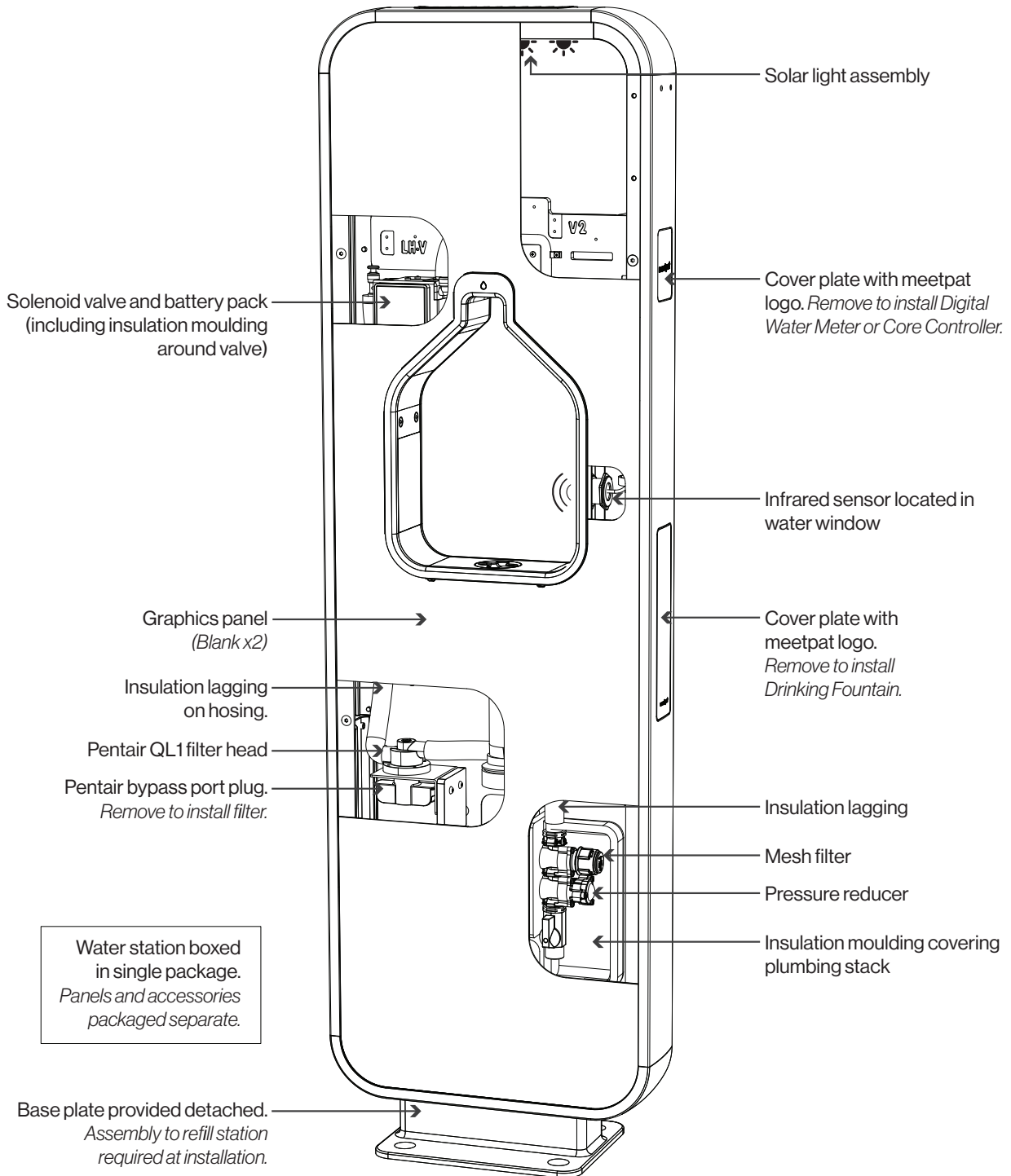

All information and images contained in the document are © Meet PAT™ - Meet PAT Pty Ltd or their respective owners. They are not be used without consent from Meet PAT™. As improvements in the design and performance of Meet PAT products are continuous, specifications may be subject to change without notice. This technical sheet is copyright and owned by Meet PAT™ - Meet PAT Pty Ltd ABN 48163544278. All rights are reserved. All products and sales are subject to Meet PAT™ terms and conditions.

Water Filter AX-FR-01

meetpat accessories

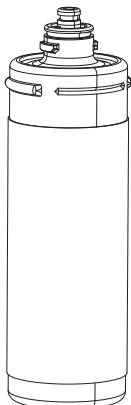

Product Description

Water filter is compatible with both permanent and portable refill stations.

Product effectively filters dirt and particles as small as 5 microns. Inhibits the growth of bacteria, reduces chlorine taste and odour and improves the taste of the water.

Compatible with all Refill Stations;
PT-RS-03 & XS-RS-03-TM & PM-RS-03 (GM & WM)

| Product Specifications & Inclusions | |
|-------------------------------------|---|
| Rated Capacity | 22,000 litres |
| Flow Rate | 3L per minute (pressure dependent) |
| Working Temp | 1°C minimum 38°C maximum |
| Service Flow Rate | 5.67 Lpm |
| Connections | Hand fit to water station. No tools required. |
| Power | No electrical connection required |
| Warranty | 1 year standard. Refer meetpat product warranty for full T&Cs. |
| Replacement | Available from meetpat. Reorder code: AX-FR-01 |

| Packaged Details | | |
|------------------|--------|--------------------|
| Product | Weight | Packed Size* |
| AX-FS-01 | tbc | cm x cm x cm |
| AX-FR-01 | 550gm | 27cm x 10cm x 10cm |
| AX-FL-01 | tbc | cm x cm x cm |

*packed size varies depending on quantity and accessories ordered

All information and images contained in the document are © Meet PAT™ - Meet PAT Pty Ltd or their respective owners. They are not be used without consent from Meet PAT™. As improvements in the design and performance of Meet PAT products are continuous, specifications may be subject to change without notice. This technical sheet is copyright and owned by Meet PAT™ - Meet PAT Pty Ltd ABN 48163544278. All rights are reserved. All products and sales are subject to Meet PAT™ terms and conditions.

**Meet Pat™ | Meet PAT Pty Ltd | meetpat.com
(02) 6021 0300, +612 6021 0300 | sales@meetpat.com**

meetpat®

Drinking Fountain Kit PM-AK-01

meetpat Accessories

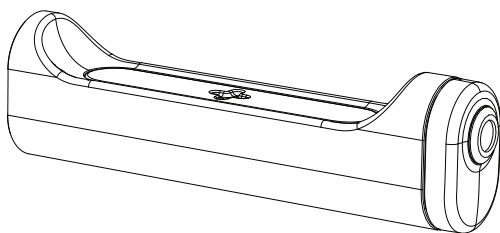

Product Description

The drinking fountain kit* is manufactured in a cast stainless steel body with a self draining system, to eliminate stagnant water and bacteria.

Combining touch free technology with lead free plumbing and anti-bacterial stainless steel nozzles. The product is DDA and ADA compliant and provides accessible, healthy drinking water for all users.

*Maximum of 2 per water station

| Product Specifications & Inclusions | |
|-------------------------------------|---|
| Tapware/ Sensor | Infrared sensor with impact resistant lens. Located at end of drinking fountain. 4x AA batteries. 100,000 activations (2-3 years for battery life) |
| Body | SU304 stainless steel |
| Nozzle | SU316 stainless steel |
| Water Pressure | Max. 500kPa operating pressure (5 bar) Min. 120kPa operating pressure (1.2 bar) |
| Flow Rate | 1.7L per minute (pressure dependent) |
| Working Temp. | 1°C minimum 38°C maximum |
| Supply Line | Press fit 1/4" tube. Connect direct to PM-RS-03 |
| Drainage | 40mm diameter PVC |
| Finished Size | 44cm x 9cm x 13cm |
| Compatibility | PM-RS-03-GM |
| Warranty | 3 year standard. 10 year structural warranty on stainless steel frame construction. Refer meetpat product warranty for full T&Cs. |

| Packaged Details | | |
|------------------|--------|--------------------|
| Product | Weight | Packed Size* |
| PM-AK-01 | 10kgs | 71cm x 25cm x 13cm |

*packed size varies depending on quantity and accessories ordered

All information and images contained in the document are © Meet PAT™ - Meet PAT Pty Ltd or their respective owners. They are not be used without consent from Meet PAT™. As improvements in the design and performance of Meet PAT products are continuous, specifications may be subject to change without notice. This technical sheet is copyright and owned by Meet PAT™ - Meet PAT Pty Ltd ABN 48163544278. All rights are reserved. All products and sales are subject to Meet PAT™ terms and conditions.

Meet Pat™ | Meet PAT Pty Ltd | meetpat.com
(02) 6021 0300, +612 6021 0300 | sales@meetpat.com

meetpat®

Tall Extension Kit PM-TK-01

meetpat Accessories

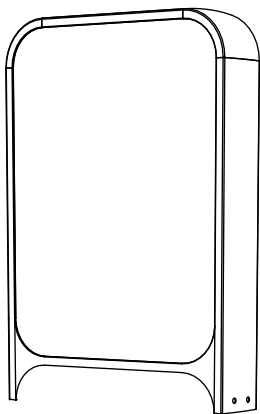

Product Description

Designed to help you stand out in a crowd.

The solar illuminated tall extension kit* is easily fitted to the top of a permanent refill station. Manufactured using the same materials and technology for a uniform appearance.

*Maximum of 1 per water station

| Product Specifications & Inclusions | |
|-------------------------------------|---|
| Frame | Aluminum (powdercoated) |
| Lighting | Solar with automatic low light sensor |
| Power | No electrical connection required |
| Finished Size | 685cm x 445cm x 10cm |
| Compatibility | PM-RS-03-GM |
| Warranty | 3 year standard. 10 year structural warranty on stainless steel frame construction. Refer meetpat product warranty for full T&Cs. |

| Packaged Details | | |
|------------------|--------|--------------------|
| Product | Weight | Packed Size* |
| PM-TK-01 | 9kgs | 75cm x 50cm x 15cm |

includes boxed: tall kit & panels

*packed size varies depending on quantity and accessories ordered

All information and images contained in the document are © Meet PAT™ - Meet PAT Pty Ltd or their respective owners. They are not be used without consent from Meet PAT™. As improvements in the design and performance of Meet PAT products are continuous, specifications may be subject to change without notice. This technical sheet is copyright and owned by Meet PAT™ - Meet PAT Pty Ltd ABN 48163544278. All rights are reserved. All products and sales are subject to Meet PAT™ terms and conditions.

**Meet Pat™ | Meet PAT Pty Ltd | meetpat.com
(02) 6021 0300, +612 6021 0300 | sales@meetpat.com**

meetpat®

Dog Bowl PM-DB-02

meetpat Accessories

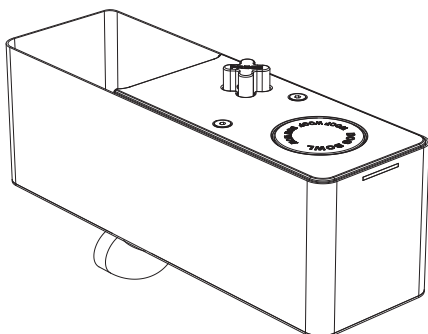

Product Description

The addition of a dog bowl with sub surface pit* manufactured in full stainless steel, delivers fresh and clean pet water.

The foot operated tap delivers a fresh serving of water each time, then self-cleans ensuring no stagnant water.

*Maximum of 1 per water station

| Product Specifications & Inclusions | |
|-------------------------------------|---|
| Sub Surface Pit | Stainless steel (4mm) |
| Finish | Stainless steel (natural) |
| Tapware | Foot operated. Press stainless steel (316) button |
| Water Pressure | Max. 500kPa operating pressure (5 bar) Min. 120kPa operating pressure (1.2 bar) |
| Flow Rate | 3L per minute (pressure dependent) |
| Working Temp. | 1°C minimum 38°C maximum |
| Supply Line | Threaded 1/2" male connection including; shut off tap and dual backflow prevention |
| Drainage | 90mm diameter PVC |
| Power | No electrical connection required |
| Finished Size | 23cm x 74cm x 23cm excluding drainage connection piece |
| Warranty | 1 year standard. Refer meetpat product warranty for full T&Cs. |

| Packaged Details | | |
|------------------|--------|--------------------|
| Product | Weight | Packed Size* |
| PM-DB-02 | 24kgs | 25cm x 75cm x 25cm |

*packed size varies depending on quantity and accessories ordered

All information and images contained in the document are © Meet PAT™ - Meet PAT Pty Ltd or their respective owners. They are not be used without consent from Meet PAT™. As improvements in the design and performance of Meet PAT products are continuous, specifications may be subject to change without notice. This technical sheet is copyright and owned by Meet PAT™ - Meet PAT Pty Ltd ABN 48163544278. All rights are reserved. All products and sales are subject to Meet PAT™ terms and conditions.

Meet Pat™ | Meet PAT Pty Ltd | meetpat.com
(02) 6021 0300, +612 6021 0300 | sales@meetpat.com

meetpat®